

FUEL VENTILATION SYSTEM - MAINTENANCE PRACTICES

1. General

- A. The fuel ventilation system is divided into two sections. One section is routed from the fuel reservoir to a cross in left wing, with lines running outboard from cross to each fuel tank. The second section includes a fuel vent line valve in each tank and lines extending outboard to each wing tip, then aft to trailing edge of wing. Each line has a 0.040 inch diameter hole drilled in the upper surface 6.50 inches from aft end of line. The fuel vent line valve, located inside each fuel tank, is equipped with a float valve that shuts off the fuel flow to the vent line any time the fuel level in the tank rises above the level of the vent line. A relief valve in the fuel vent line valve opens at 0.7 PSI negative pressure and 1.0 PSI positive pressure to prevent fuel starvation or tank damage.

2. Vent Lines and Valve Removal/Installation

- A. Remove the Vent Lines and Valve (Refer to Figure 201).
- (1) Remove the wing tip assembly. Refer to Chapter 57, Wings - Removal/Installation.
 - (2) Remove the lower wing surface access covers adjacent to the vent lines, fuselage access cover on fuselage below reservoir and the left and right sidewall panels aft of pilot's and copilot's entrance doors. Refer to Chapter 6, Access Plates and Panels Identification - Description and Operation.
 - (3) Remove the fuel from the fuel tanks. Refer to Fuel Systems - Maintenance Practices.
 - (4) Do a purge of the fuel tanks. Refer to Fuel Systems - Maintenance Practices.
 - (5) Disconnect tube nut, remove nut and O-ring discard ring.
 - (6) Remove the fuel vent valve from the fuel bulkhead.
 - (7) Remove the fuel vent line valve from the fuel tank.
 - (8) Remove the washer from the fuel vent line valve.
 - (9) Remove the nuts and screws from the clamps and jumper wire.
 - (10) Disconnect the jumper wire from the clamps.
 - (11) Loosen the clamps and disconnect the hose from the wing tip vent line and the vent line. Discard the hose.
 - (12) Remove the screws from the clamp and disconnect the grommet from the wing rib. Remove vent line from the wing.
 - (a) Make sure that the hole in the tube is not plugged.
 - (13) Loosen the tube nuts and remove the union.
 - (14) Remove the bolts and detach the retainers from the root rib.
- B. Install the Vent Lines and Valve (Refer to Figure 201).
- (1) Replace the union and attach the tube nuts.
 - (2) Attach the vent line to the wing.
 - (3) Connect the grommet to wing rib.
 - (4) Attach the clamp to the wing rib and replace the screws.
- CAUTION: The end of the wing tip vent line must project 0.50 inch, +0.03 or -0.03 inch beyond the wing trailing edge to supply even fuel flow from left and right sides of the system.**
- (5) Attach the hose to the vent line and wing tip vent line.
 - (6) Install and tighten the clamps.
 - (7) Attach the upper wires to the clamps. Install the screws and nuts.
 - (a) Make sure the jumper wires and clamps are bonded.
 - (b) After you install all the jumper wires in the system, check the resistance with an ohmmeter. The maximum allowable resistance must show 0.01 ohm.
 - (8) Attach the washers to the fuel vent line valves.
 - (9) Attach the fuel vent line valves to the fuel bulkhead. Replace the O-rings and nuts.
 - (10) Attach and tighten the tube nut to the fuel vent line valve.
 - (11) Seal and clean the fuel tanks.
 - (12) Install the wing tip assemblies. Refer to Chapter 57, Wings - Removal/Installation.

- (13) Install the lower wing access covers, fuselage access cover, and sidewall panels. Refer to Chapter 6, Access Plates and Panels Identification - Description and Operation.
- (14) Put fuel in the fuel tanks. Refer to Chapter 12, Fuel - Servicing.
- (15) Do a check for leaks.

3. Union, Tubes and Cross Removal/Installation

- A. Remove the Union, Tubes and Cross (Refer to Figure 201).
 - (1) Loosen the tube nuts and disconnect tubes from the union.
 - (2) Remove the nut and ring from the union.
 - (3) Discard the ring and disconnect the union from the fuel bulkhead.
 - (4) Loosen the clamps and disconnect the tubes and hoses from the cross. Discard hoses.
 - (5) Disconnect the hoses from the tubes and cross. Remove the cross.
 - (6) Remove the bolts. Disconnect the upper shield halves and lower shield halves from the floorboard rib.
 - (7) Remove and discard the seals.
 - (8) Remove the nut from the screw and disconnect the vent line clamps from the fuel line clamps.
- B. Install the Union, Tubes and Cross (Refer to Figure 201).
 - (1) Locate the seals on the tubes. Attach the upper and lower shield halves to floorboard ribs. Replace bolts.
 - (2) Attach the union to the fuel bulkhead.
 - (3) Install the O-ring and nut.
 - (4) Attach and tighten the tube nuts on the union.
 - (5) Attach the hoses to the cross, tubes and tighten the clamps.
 - (6) Attach and tighten the tube nut on the union.
 - (7) Attach the hoses to the tubes and tighten the clamps.
 - (8) Install the screws in the clamps, attach and tighten nuts on the screws.
 - (9) Install the union and tighten the tube nuts.
 - (10) Attach the retainers to the root ribs and install the bolts.

4. Seals and Reservoir Vent Lines Removal/Installation

- A. Remove the Seals and Reservoir Vent Lines (Refer to Figure 201).
 - (1) Remove the screws from the lower shield half and upper shield half.
 - (2) Loosen the clamps and remove the vent tube from the hose. Remove and discard the hose.
 - (3) Loosen the tube nut.
 - (4) Disconnect the tube from the manifold.
- B. Install the Seals and Reservoir Vent Lines (Refer to Figure 201).
 - (1) Attach the tube to the manifold and tighten the nut.
 - (2) Install the hose on the reservoir.
 - (3) Attach the tube to the hose and tighten the clamps.
 - (4) Attach the seal to the tube, locate upper and lower shield halves and install the screws.

5. Fuel Vent Line Float Valve Test

NOTE: The fuel vent line float valve can become plugged causing possible fuel starvation of engine. The following procedure must be used to check the function of the fuel vent valve.

- A. Do a valve test of the fuel vent line float.
 - (1) Attach a rubber tube end to one wing tip vent line.
 - (2) Do a check to make sure the fuel caps are correctly installed and the fuel selector valve is turned off.
 - (3) Put a plug in the 0.040 inch diameter hole in the wing tip vent line located 6.50 inches from the end of the part.
 - (4) Blow into the tube to slightly pressurize fuel tank (if air can be blown into tank, vent lines are open and float valve is not plugged).

- (a) If air cannot be blown into the fuel tank, remove the vent lines and fuel vent line valve from the system.
 - 1 Clean the vent lines.
 - 2 Do a functional check of the fuel vent line valve.
 - 3 If the float valve sticks or the relief valve does not open at 0.7 negative PSI or 1.0 PSI, replace the fuel line vent valve.
- (5) Repeat steps 5.A.(1) through 5.A.(4)(a)3 for the opposite fuel tank.
- (6) Remove the tube and plug from the wing tip vent line.

Figure 201 : Sheet 1 : Fuel Vent System Installation

A22434

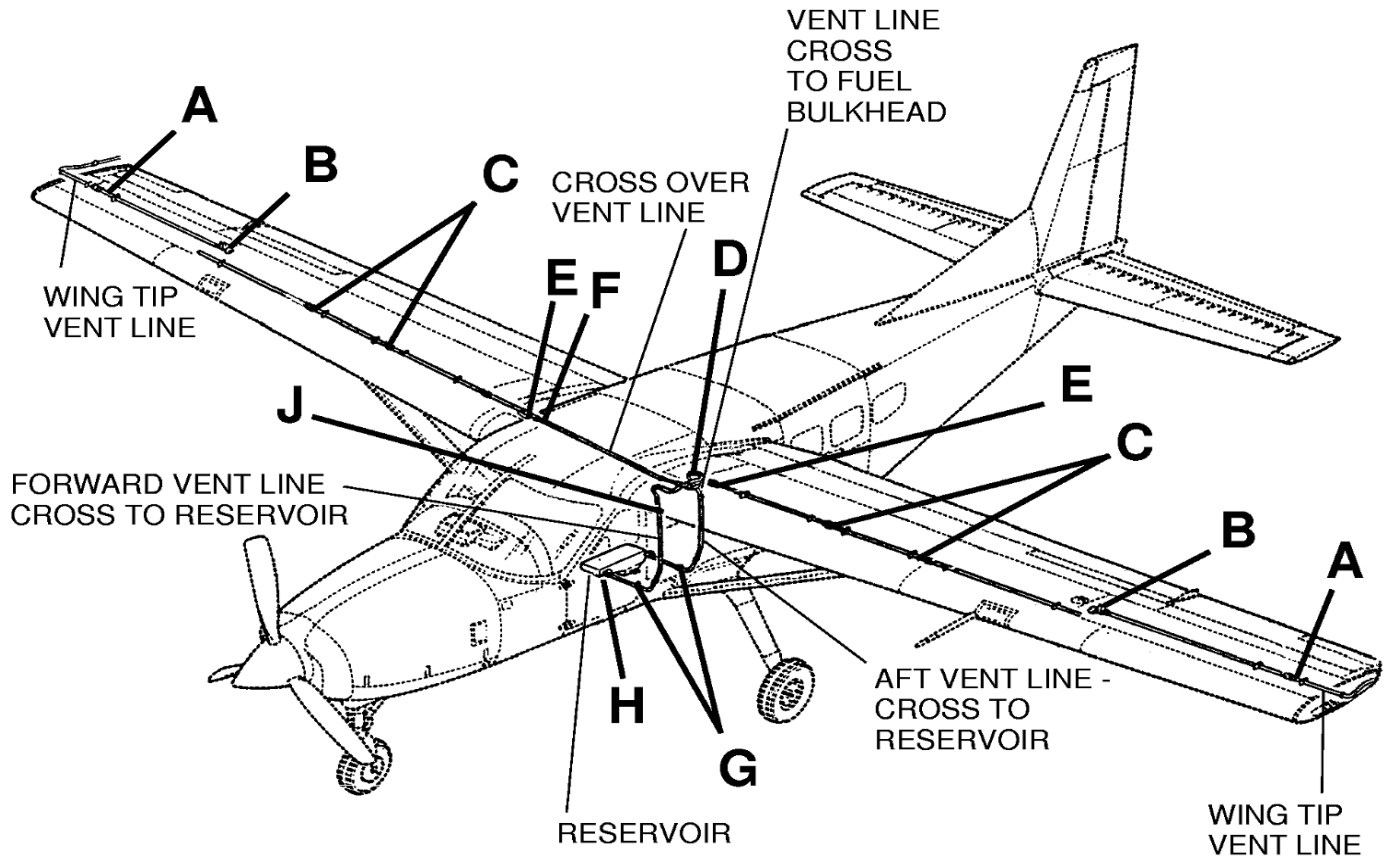

26262003

Figure 201 : Sheet 2 : Fuel Vent System Installation

A22437

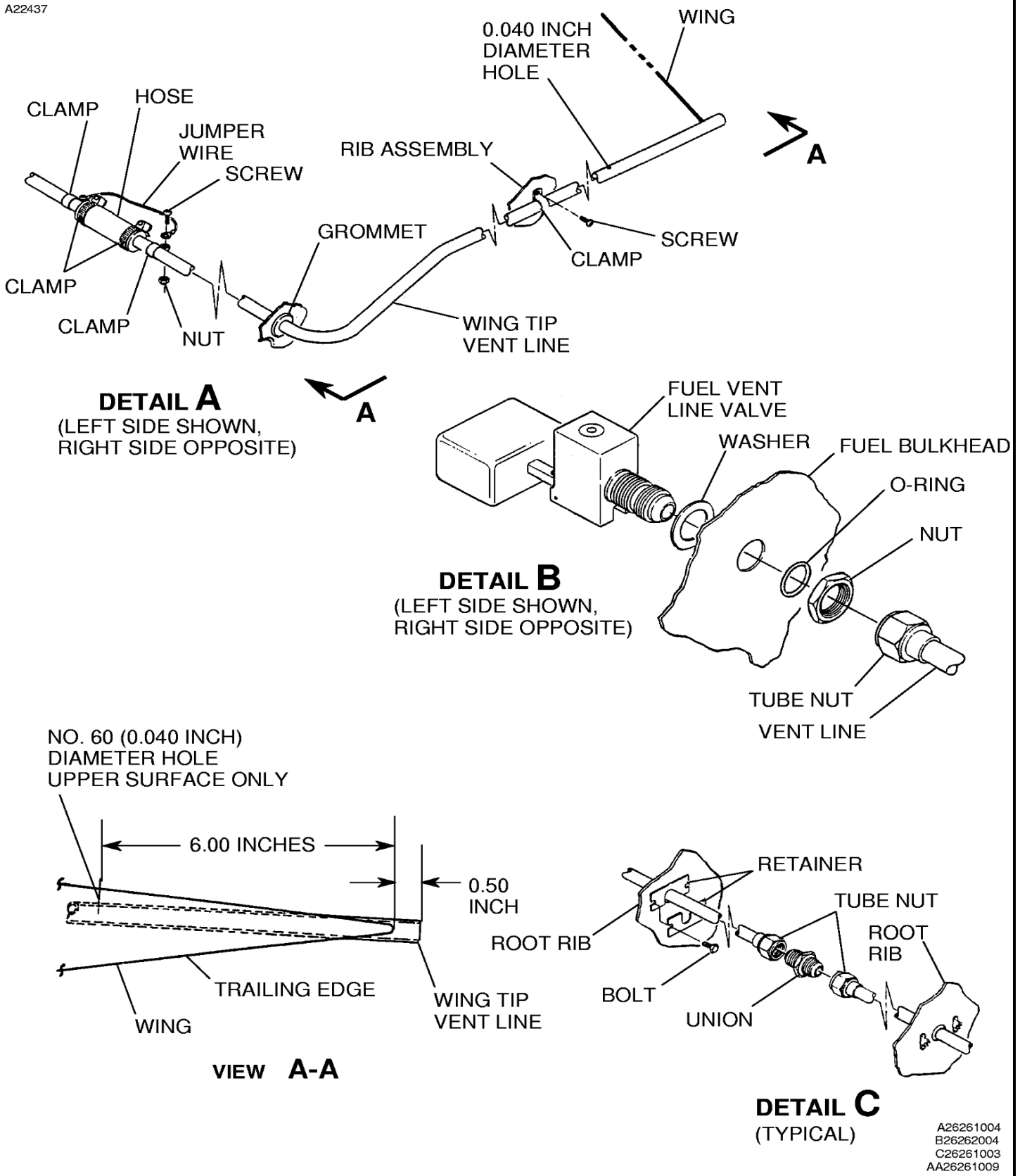

A26261004
 B26262004
 C26261003
 AA26261009

Figure 201 : Sheet 3 : Fuel Vent System Installation

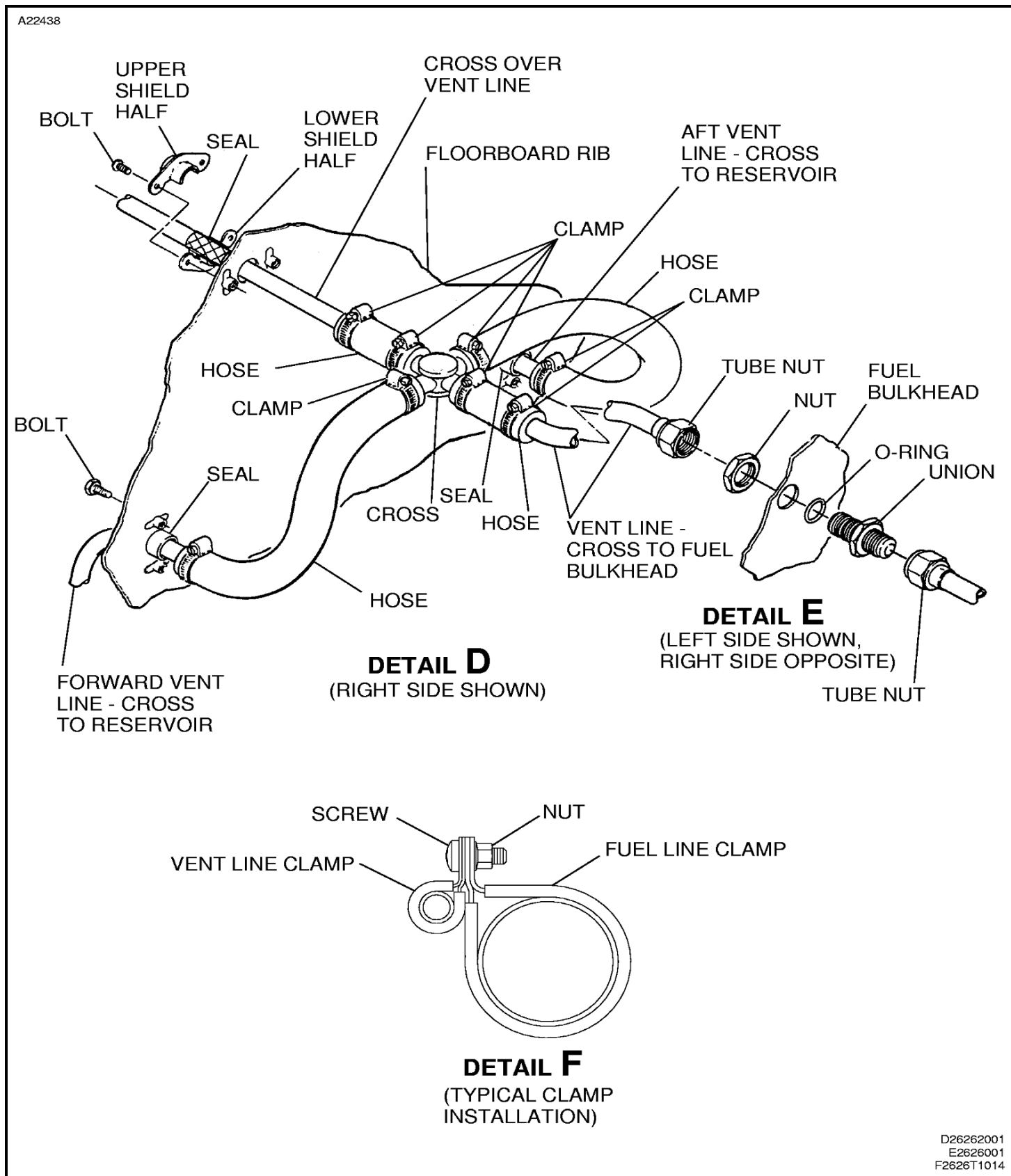
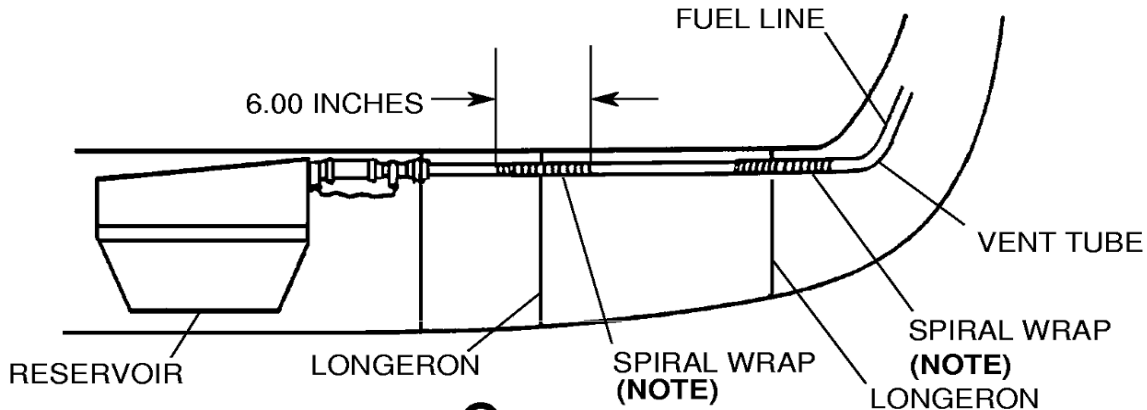

Figure 201 : Sheet 4 : Fuel Vent System Installation

A22440



DETAIL G
 (RIGHT SIDE SHOWN)

NOTE: INSTALL TWO 6.00 INCH SPIRAL WRAPS ON EACH LINE IN PLACE OF CLAMPS.

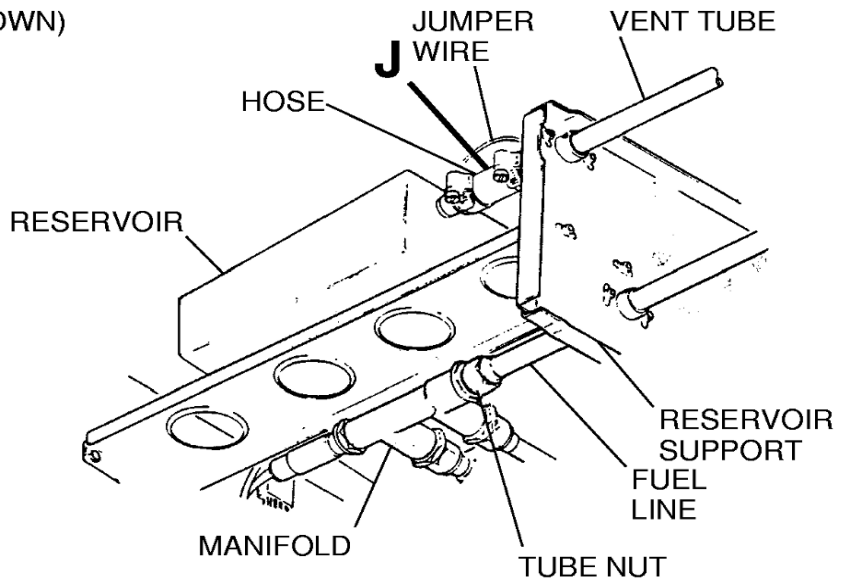

DETAIL H
 (RIGHT SIDE SHOWN)

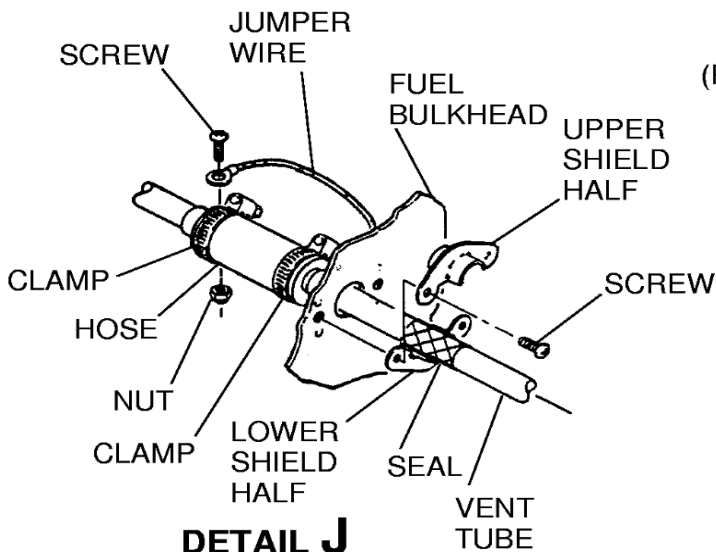

DETAIL J
 (RIGHT SIDE SHOWN)

H2626R1016
 G2626R1017
 J2626R1015